

The Human Rights Watch Report of May 1, 2013 Cites Evidence that Disaffirms Its Own Conclusions About the Alleged Nerve Agent Attack at Khan Sheikhoun in Syria on April 4, 2017

Theodore A. Postol
Professor Emeritus of Science, Technology, and National Security Policy
Massachusetts Institute of Technology

Introduction

This note discusses evidence cited in the *Human Rights Watch Report (HRW)* of May 1, 2017 that claims to prove that the Syrian government used an airdropped munition in an alleged nerve agent attack in Khan Sheikhoun, Syria on April 4, 2017. The report only shows forensic evidence that disaffirms its conclusions. I will focus on the Report's claim of evidence for an alleged airdropped munition since that is central to the entire *HRW* analysis and demonstrates the near complete lack of forensic proof and professional standards of analysis in the overall report.

I quote from the relevant section of the report for the convenience of the reader:

Human Rights Watch reviewed dozens of photos and videos provided by residents of a crater from the impact of the first bomb. [Emphasis Added] Local residents believed this site was the source of the chemical exposure because those who died lived nearby and people who came near it, including first responders, exhibited the strongest symptoms of chemical exposure. One of the first photos of the crater, taken by first responders, shows what appears to be liquid on the asphalt. That would be consistent with the use of a bomb containing sarin, which is in liquid form at room temperature.

The photos and videos of the crater show two remnants from the chemical weapon used: a twisted thin metal fragment with green paint and a smaller circular metal object. Green coloring is widely used on factory-produced weapons to signify that they are chemical weapons. The KhAB-250, for example, one of two Soviet-produced bombs specifically designed to deploy sarin from a warplane, has two green bands. The circular object seen in photos of the crater appears similar to the cap covering the filling hole on the KhAB-250.

These remnants, combined with witness observations, the victims' symptoms, and the identification of sarin as the chemical used in the attack by the French and Turkish governments and the Organization for the Prohibition of Chemical Weapons, suggest that the Syrian warplane dropped a factory-made sarin bomb. According to open source material, the only Soviet-produced bombs designed specifically to deliver sarin are the KhAB-250 bomb, and its bigger version, the KhAB-500. [Emphasis Added]

Evidence suggests that the Khan Sheikhoun attack is not the first time government warplanes have dropped nerve agents in recent months. Witnesses described to Human Rights Watch symptoms consistent with exposure to nerve agents that they and other local residents experienced after warplanes attacked eastern Hama on December 11 and 12 and northern Hama, near Khan Sheikhoun, on March 30, 2017.

The December attacks were in territory controlled by the Islamic State (also known as ISIS), which closely monitors communication, so it has been difficult to reach witnesses. But four witnesses interviewed by phone and two medical personnel interviewed via text message through intermediaries gave consistent accounts of the attacks. An opposition-affiliated activist and local residents provided the names of 64 people who died from chemical exposure in the December attacks.

<https://www.hrw.org/report/2017/05/01/death-chemicals/syrian-governments-widespread-and-systematic-use-chemical-weapons>

The KhAB-250 and KhAB-500 airdropped munitions identified by *HRW* are designed to dispense sarin by bursting at low altitude in the air, creating an aerosol cloud of nerve agent-droplets that are carried downwind as they fall from the point of the airburst (see diagrams and photos on page 5 of 13 pages).

A properly functioning "250" or "500" munition would *not* create the crater that is the focus of the *HRW* analytical conclusion that there is evidence that this munition was used.

However, if the munition malfunctioned and hit the ground, as alleged by *HRW*, there would be a crater as alleged by *HRW*. As will be explained later in this report, the crater and the area around it would contain a large amount of distinctly identifiable pieces of debris; including the entirely intact tail section of the munition, sheets of shattered and twisted thin-walled metal sections of the sarin-containing vessel, the front flat face of the munition, and other large, distinct, and easily identifiable pieces of munitions-remnants.

The *HRW* claim that their analysis shows that this “standard” Russian munition was the source of the sarin release is therefore unsupported by the observed evidence they put forward. Put in other words, the *HRW* report does not contain any basic forensic evidence to support its claim that a standard Russian munition was the source of a sarin release at the crater.

A crater produced by the impact and detonation of the internal explosive “burstor” tube of a KhAB-250 and KhAB-500 munition would be filled with soil that was saturated with tens of liters of highly toxic sarin. Since the evaporation rate from the saturated soil would be slow relative to sarin deposited on the flat surrounding road surface, the area in and around the crater could have easily been highly toxic for 5 to 10 or more hours after the impact. During this period it would have not been possible for “White Hats” without hazmat protective equipment to dig inside the crater or linger in the immediate area around the crater, as observed in videos.

If the alleged munition had worked as designed, the munition would have burst in the air and created a cloud of sarin droplets. Lethal concentrations of sarin droplets would have rained down relatively quickly over large parts of the densely populated area. Almost nobody in the target area where larger droplets of sarin fell would have had time to escape with their lives.

If instead the crater at issue was the location of a malfunctioning KhAB 250 or 500 “standard” Russian munition the evidence for such a munition would be substantial and unambiguous. Based on the data provided in the *HRW* report and the extensive news videos and photos of the same crater referred to by *HRW*, it is possible to reach solid forensic-based conclusions about the claims put forward in the *HRW* report. Those conclusions are as follows:

1. There is no forensic evidence presented in the *HRW* report to support the allegation that the munition used to deliver sarin was a KhAB 250 or 500 “standard” Russian munition.
2. There is no forensic evidence of any kind of debris in and around in the crater that indicates any form of airdropped sarin dispensing munition.
3. There is no forensic evidence of a calamitous killing of a large part of the population of a densely populated area immediately adjacent to the alleged crater where massive amounts of sarin were supposed to have been released.
4. Interviews described in the *HRW* report were not verified in any way.

One of the most striking omissions in the panoply of claims put forth in the *HRW* report is the lack of any video evidence (or verbal accounts) of mass casualties and chaos in the densely populated area immediately adjacent to the crater that would have had to be the alleged sarin kill-zone.

Instead, as will be shown below, the only indication of a death near the crater is videos of a goat carcass that was obviously dragged across the ground to the location. The same people who took these videos appear to be among the “reliable” sources of interview evidence cited by the *HRW* report. These same journalists showed a dead carcass of a goat supposedly adjacent to the crater rather than the area where mass casualties would have occurred an equally short distance away.

5. Although there are pictures of victims that indicate poisoning by sarin or other organophosphates that act as nerve agents, there is no forensic indication that these photographs are actually victims of sarin poisoning in the alleged nerve agent attack of April 4, 2017 in Khan Sheikhoun. If the victims could be connected with an event in Khan Sheikhoun on April 4, their symptoms could easily be the result of poisoning from organophosphates pesticides and from gases and smoke products generated in fires that often occur in industrial accidents. As such, there is no basis to rule out a claim made by the Russians that an ammunition dump that was adjacent to a heavily populated area was hit using a conventional explosive bomb. While this certainly is not proof of the Russian claim, neither is there any proof in the *HRW* report of a sarin release at the crater.
6. Given that there is substantial evidence that groups other than the Syrian government possess sarin precursors, indications of sarin poisoning do not alone indicate that the Syrian government was the source of the sarin, assuming the observed medical effects were from sarin.

HRW Claims About the Airdropped Sarin-Dispersing Munition Used in Khan Sheikhoun

The conclusions based on the alleged technical analysis of the crater where sarin was released as reported in the *HRW* report of May 1 are in part summarized in the pastiche of “photographic evidence” below.



<https://www.hrw.org/report/2017/05/01/death-chemicals/syrian-governments-widespread-and-systematic-use-chemical-weapons>

This crater was first identified in the White House Intelligence Report of April 11, 2017. *HRW* argues that these photos show evidence for a sarin dispersal by either a “standard” Russian KhAB 250 or KhAB 500 sarin dispersing bomb.

The munition *HRW* refers to has many variants. Some variants contain high explosives and have a thick casing to create lethal fragments. Other variants are constructed with thin metal walls and contain submunitions. This second thin-walled variant could also be used to dispense bulk sarin instead of a submunition payload. It could also be used to dispense submunitions that carry nerve agents.

The basic dimensions of this class of munition vary slightly depending on their end-purpose. However all of the variants are designed so that they can be interchanged with bombs of similar size on the undercarriage of aircraft. This standardization of dimensions is a typical engineering practice in modern militaries.



The two above photos show technicians attaching FAB 250 bombs to the undercarriage of an aircraft. This variant of the munition could be a high explosive bomb weighing about 250 kg (about 550 pounds) or possibly a bomb that carries submunitions that are dispersed over a target. The standard munition is simply the equivalent of the 500 pound bomb used by the United States Air Force.

The KhAB 250 munition would be able to deliver an enormous amount of sarin – roughly between 60 to 70 liters of sarin within tens of meters of the heavily populated area that is immediately downwind from the alleged sarin release point.

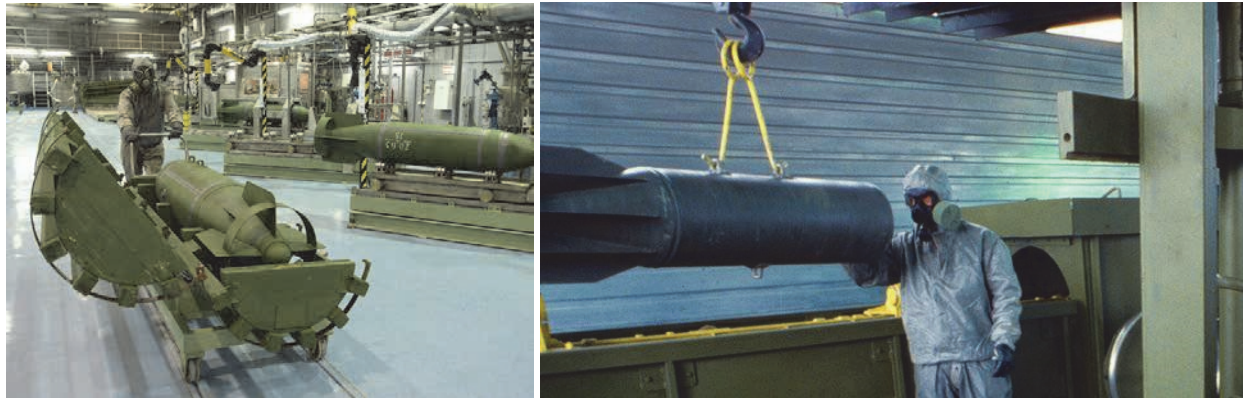

Two photographs of munitions that are closely related to the KhAB 250 and 500 munitions. Note that the bomb in the photograph on the left has a rounded knob at its back end. Other variants have a flat end-section on the back of the tailfin assembly.

If a sarin release was instead from a KhAB-500 munition, it would have delivered between 160 and 170 liters of sarin causing even larger immediate deaths and casualties within the area downwind of the crater.

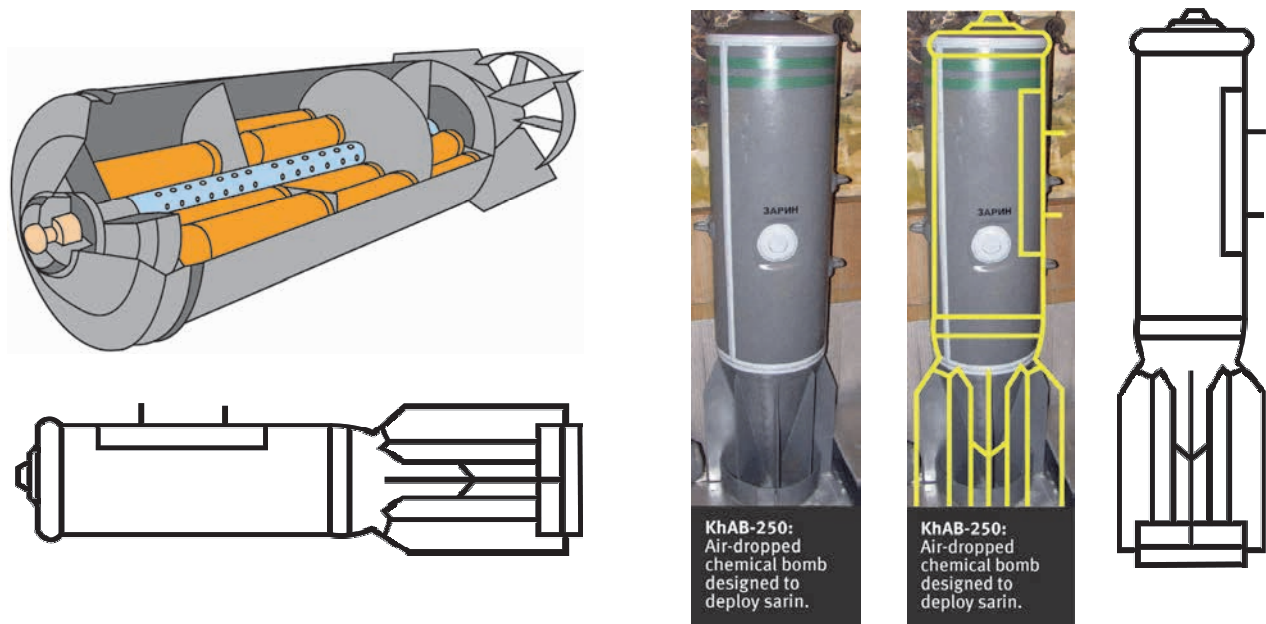

Variants of the KhAB 250 shown in the *HRW* report. Note that the variant that carries submunitions has a rod filled with explosives running down the center of the casing. The rod has holes in it so that the exploding munitions will not pressurize the container too fast with hot gas products from the explosive. The unusual flat face on the munition holds the explosive rod in place and contains a fusing mechanism that determines when the intended disintegration of the munition will occur.



The sequence of video frames above show an FAB 250 or FAB 500 variant deploying submunitions over a target. The chemical variant of the bomb would work in a similar way. The explosive tube that runs down the center and length of the sarin-containing munition would be detonated at a predetermined altitude. The altitude could be set so as to take maximum advantage of the weather conditions over the target. The most ideal conditions for maximum casualties against unprotected civilians are low wind speeds and cool surface temperatures, as was the case in Khan Sheikhoun at the time *HRW* alleges the airdropped munition attack.

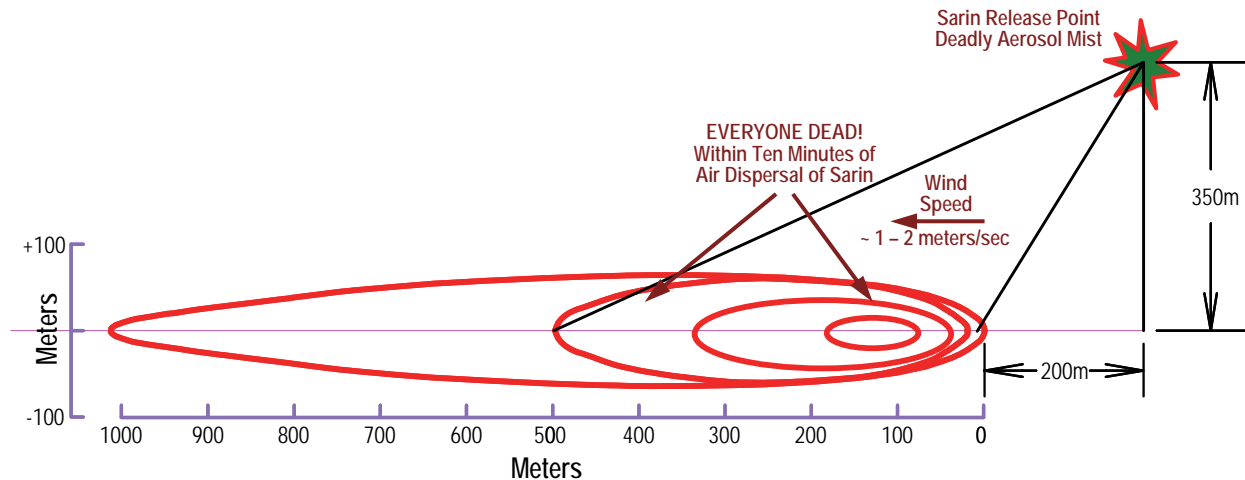

This diagram shows how a properly functioning KhAB 250 or 500 nerve agent dispersing munition would deliver its deadly load to a target. For the particular munition size and wind conditions a dispersal altitude of 200 to 300 m would be near ideal for delivering an aerosol of nerve agent to the intended target area. By opening up the munition with an explosive charge, the nerve agent would be blown out into a cloud of tiny droplets of varying size. Larger droplets would fall more quickly than smaller droplets. The larger droplets would reach the ground first in the smaller droplets would reach the ground later in would be carried further downwind by the ambient slow moving air. If a sarin release is able to achieve 1 or 2 g/m² on the ground, this would be adequate for killing those in the target area. Such a density of sarin on the ground could easily evaporate into gas concentrations of 50 to 100 mg per cubic meter, which would kill unprotected individuals within roughly a minute. An important feature of this kind of dispersal is that areas downwind of the immediate dispersal have the potential to be highly lethal even though droplets of sarin may not have been deposited at those locations. This is because areas where relatively large sarin droplets are deposited would create a local environment of constantly evaporating sarin that would then be trapped by the stable air and carried downwind by the gentle prevailing wind. As such, the extent of the area that would be affected is highly unpredictable, but it could well extend to distances of 400 to 500 m from the front-end of the contaminated region.

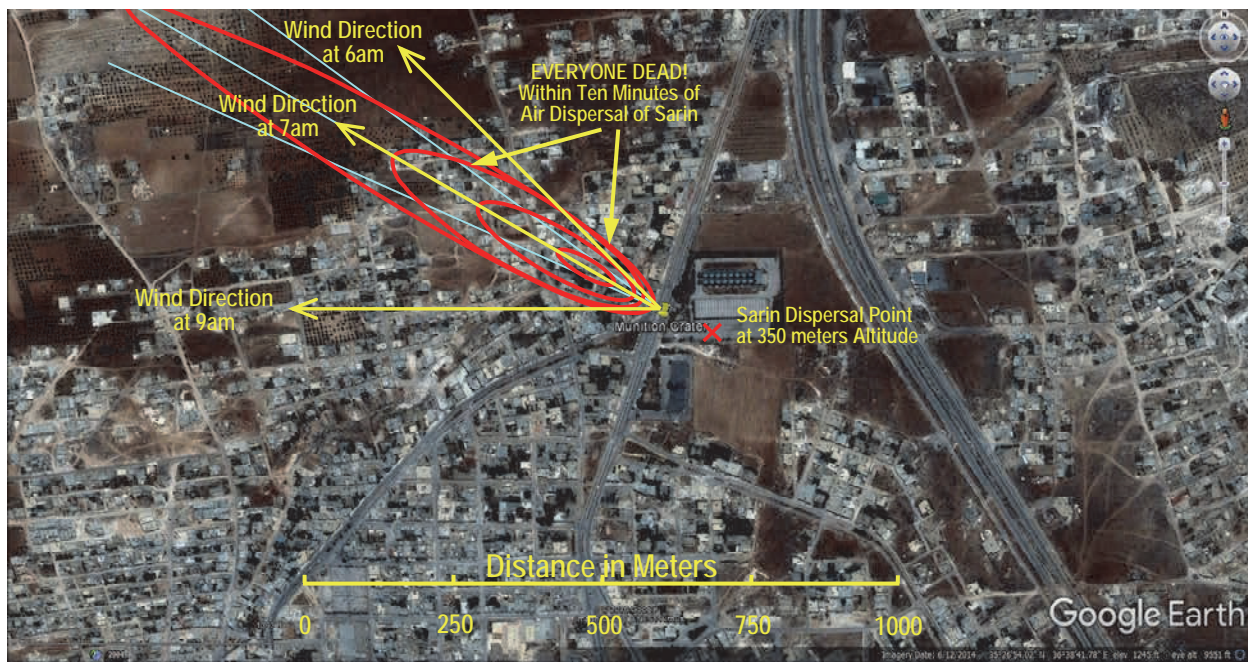

The marked up photograph above shows the situation that could have occurred if a KhAB 250 or 500 sarin-dispersing munition properly functioned and detonated in the air if it was used in the attack. The location of the air dispersal point is shown as a red cross on the photograph.

HRW Claims About the IMPACT Crater in Khan Sheikhoun

A critical claim in the *HRW* report is that their analysts extensively reviewed photos and videos associated with the impact crater. This is an important claim, since such a review should have shown clear forensic evidence to knowledgeable analysts that the crater was produced by a KhAB-250 or 500 munition. The observable evidence to support their claim is described in this section.

The comments about the allegedly thorough analysis of the crater done by *HRW* analysts are quoted below for the convenience of the reader:

Human Rights Watch reviewed dozens of photos and videos provided by residents of a crater from the impact of the first bomb. Local residents believed this site was the source of the chemical exposure because those who died lived nearby and people who came near it, including first responders, exhibited the strongest symptoms of chemical exposure. One of the first photos of the crater, taken by first responders, shows what appears to be liquid on the asphalt. That would be consistent with the use of a bomb containing sarin, which is in liquid form at room temperature.

Other related statements refer to additional information that cannot be relied upon. This is also quoted below for the convenience of the reader:

Evidence suggests that the Khan Sheikhoun attack is not the first time government warplanes have dropped nerve agents in recent months. Witnesses described to Human Rights Watch symptoms consistent with exposure to nerve agents that they and other local residents experienced after warplanes attacked eastern Hama on December 11 and 12 and northern Hama, near Khan Sheikhoun, on March 30, 2017.

The December attacks were in territory controlled by the Islamic State (also known as ISIS), which closely monitors communication, so it has been difficult to reach witnesses. But four witnesses interviewed by phone and two medical personnel interviewed via text message through intermediaries gave consistent accounts of the attacks. An opposition-affiliated activist and local residents provided the names of 64 people who died from chemical exposure in the December attacks.

Still other statements made in the *HRW* report raise further questions about *HRW* conclusions that there was evidence of a nerve agent attack, rather than an event that could have resulted in the poisoning of residents near an ammunition dump that had been hit with a conventional explosive bomb. For example, the *HRW* report states that "Witnesses described to *Human Rights Watch* symptoms consistent with exposure to nerve agents [emphasis added]."

If an ammunition dump was hit, there would certainly have been secondary explosions and fires. If the storage site contained sarin precursors, organophosphorus pesticides and plastic drums and containers, victims downwind of the immediate detonation and fire zone could well show all of the symptoms reported by *HRW*. As discussed in an earlier report, although the disaster at Bhopal, India in December 1984 did not involve the release of a nerve agent, it produced many symptoms like foaming at the mouth that are often associated with a nerve agent attack. If similar types of lung destroying gases were mixed with organophosphates, the symptoms could well match all those described in the *HRW* report as proof of the nerve agent attack.

Organophosphorus containing pesticides used in the Middle East include Malathion, Diazinon, Glyphosate, Methamidophos, Dimethoate, Chloropyrifos, Parathion, and other Organophosphates. Acute poisoning from such agents can result in essentially all of the symptoms that have been ascribed to sarin exposure.

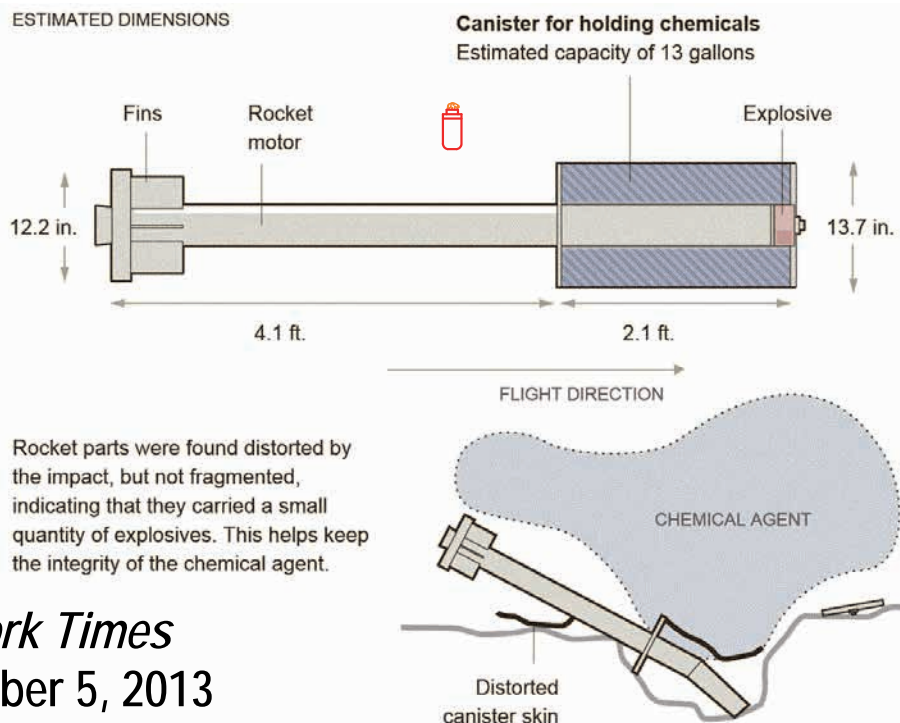

New York Times September 5, 2013

The above graphic was published by the *New York Times* in an article on September 5, 2013. The article reported our conclusions about the design and dimensions of the sarin-carrying munition derived from analysis of debris at impact craters using photographs and videos posted on the internet after the August 21, 2013 nerve agent attack in Damascus. The *Times* article was of high interest when it was published because it explained how the attackers were able to deliver roughly 10 times more sarin per rocket launched relative to what people believed shortly before the article was published. Two weeks later the UN published their inspection report and agreed with our analysis results within two decimal places of precision. When we continued our analysis and found that the range of the munition was far too short to be fired from Syrian government controlled territory, the *New York Times* was extremely reluctant to publish our new and equally important rock-solid findings. After extensive frustrations with getting the *Times* to acknowledge any facts that contradicted their then and current narrative, we conclude that this was likely because the *New York Times* had already run a first page article with graphics from another misleading *HRW* report that had incorrectly asserted the sarin-carrying munition had a range five times larger than that found by Lloyd and me, and later confirmed by the UN. We attempted to discuss our findings with analysts at *Human Rights Watch*, but they were totally unresponsive. *Human Rights Watch* has been kept fully informed of every piece of the forensic-based current analyses, but asserts entirely different analytic conclusions even though they are unable to show any forensic evidence in support of their "discoveries."

If the conditions that created the crater were due to the impact of a particular kind of munition, the detailed photographic and video studies of *HRW* would have revealed clear and unambiguous information about the character of the sarin dispensing munition.

It was exactly this kind of forensic analysis that resulted in my colleague, Dick Lloyd, and me identifying the details of the munition that was used in the Damascus nerve agent attack of August 21, 2013 (see photograph at the top of next page).



In the case of the August 21, 2013 attack the munition was designed to create a pool of sarin on the ground. The sarin saturated an area of soil in a small crater and then relatively slowly evaporated from the ground, creating a persistent smokestack-like plume downwind. Since the attack occurred at around 3 AM in the morning, people were asleep and not aware that they were being poisoned.

What probably happened was that the concentrations of sarin in many downwind locations was low enough to initially cause symptoms of sarin poisoning (apparent dimming of vision, nausea, defecation, headache) which either caused some people to awake or caused concern among people who were still awake. These people became aware that something was happening as they began communicating with others who were showing similar initial symptoms of low level poisoning. Hysteria must have broken out in the areas where people became aware that others had similar symptoms and this would have led to some sleeping people being awakened.

In other locations, people might have been sleeping undisturbed. These people were unlucky enough to remain in the downwind sarin plume long enough to be killed.

During this horrifying event, it is very likely that people were *not* aware that they were being poisoned by sarin, although they were certainly aware that something unusual and very terrifying was happening. As a result, people would not have known where to go to get out of the sarin plumes, and even if they were aware that the symptoms were from sarin poisoning, without knowing where the munitions had fallen they would not have known where to move for safety.

This chilling atrocity was therefore quite close to the expected evolution of events that would have followed in the case of Khan Sheikhoun attack – if in fact a sarin attack was executed with a KhAB 250 or 500 airdropped munition.

One important distinction between the August 21, 2013 Damascus attack and the alleged Khan Sheikhoun attack is that multiple munitions were used in the Damascus attack. This led to the creation of multiple poisonous plumes.

In some cases, the munitions in Damascus landed in open areas and although they were capable of causing toxic effects on individuals downwind, the concentration of sarin might have been too low to cause deaths but would certainly have contributed to the mass hysteria and sickening of people.

In Khan Sheikhoun, the particular munition fell only tens of meters from a densely populated area. Because of the close proximity to a release of so much sarin, the number of immediate deaths in the targeted area would have been high.

What About the Infamous *Human Rights Watch* IMPACT Crater?

If the fuse on a KhAB 250 or 500 airdropped munition malfunctioned, the munition would have gone to the ground with the casing shattering from the impact along with an almost certain detonation of the “burstor” explosive tube. Since the burstor charge is intentionally designed to be small, only enough to shatter the casing and disperse the surrounding sarin, the crater identified by *Human Rights Watch* and the White House could have been generated by such an event.



Photograph of the crater after “White Helmets” dug out the piece of metal that the *Human Rights Watch* report alleges is evidence of debris from a KhAB 250 or 500 Russian bomb. Note that the debris shown in the *Human Rights Watch* pistache of photographs (on page 3 of this document) was sticking vertically in the ground and largely buried. After the crater was tampered with the same piece of *pipe* was moved to the top of the altered crater. Note that this pipe looks nothing like any piece of a larger munition. It is crushed from the outside, which is incompatible with any action on any component of the alleged KhAB munition. In fact, absolutely nothing in the crater looks anything like any piece of a KhAB 250 or 500 munition casing.

However, if these events led to the formation of the crater, there would be large pieces of the original bomb scattered around the crater. For example, a relatively massive front plate, the extremely rigid and strongly constructed tailpiece, and large pieces from the sarin-containing vessel. A notional diagram of what the pieces might look like is shown below.

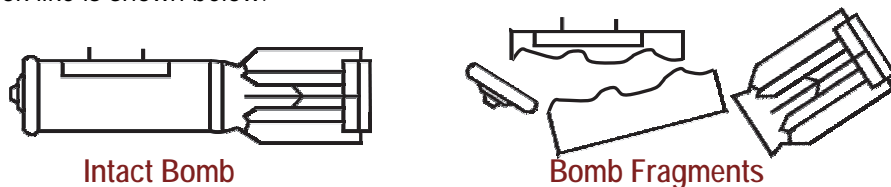

The images above show a notional drawing of the types of fragments that would be associated with the ground detonation of an KhAB 250 or 500 Russian bomb. The pieces would be unmistakable, and they would either be in the crater or in very close proximity to the crater. This would simply be because the internal explosive charge would be small and could not launch any of the pieces far from the crater. In particular, the tail section would almost certainly be in place. It is constructed from very heavy metal and the burstor tube would generate explosive forces mostly perpendicular to the axis of symmetry of the tail section.

It is therefore clear that the *Human Rights Watch* analysts had no idea about what forensic evidence to look for but reached their conclusions even in the face of evidence to the contrary.



Video frame from a video-report about the Khan Sheikhouh nerve agent attack of April 4. The early part of the video shows journalists reporting from the crater of the sarin release-site alleged by *HRW*. This photo from the same video is of a different crater that contains an unexploded bomb that survived the impact fully intact – demonstrating the rugged construction of the different components.

Dead Goats and Other Stuff

As mentioned in a report I published earlier, journalists and “White Hats” were around the crater of concern shortly after the alleged sarin attack. There can be absolutely no question that the populated area immediately next to the crater would have been massively affected from the postulated attack. This would have been a result of the wind direction and speed at the time of the attack.

Hence, if the attack occurred at the location alleged by *Human Rights Watch* the location of mass casualties would have occurred within tens of meters to the east northeast of the alleged sarin release point.

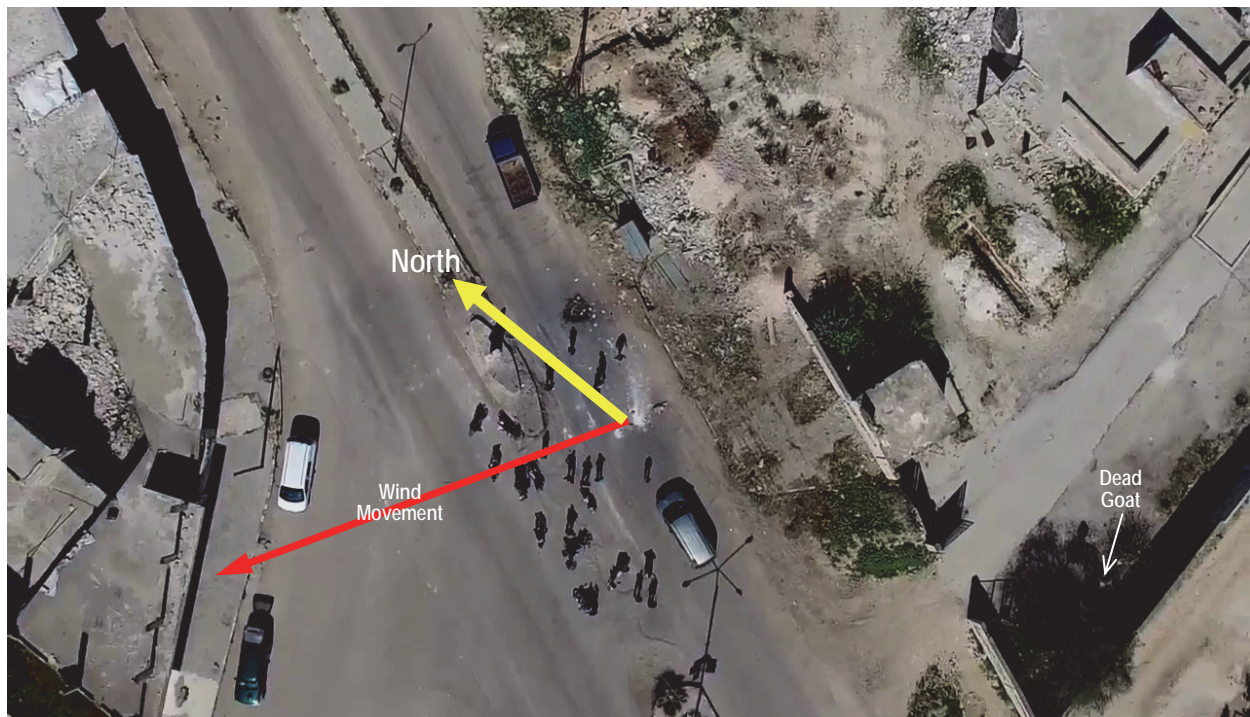

The above photo shows an aerial view of the crater where the alleged sarin release occurred. These images were taken from a drone that was used by a crew of journalists reporting at the scene. The yellow arrow shows North and the red arrow shows the direction of the wind at the time of the alleged sarin release, which would have occurred at about 7 AM on the morning of April 4.

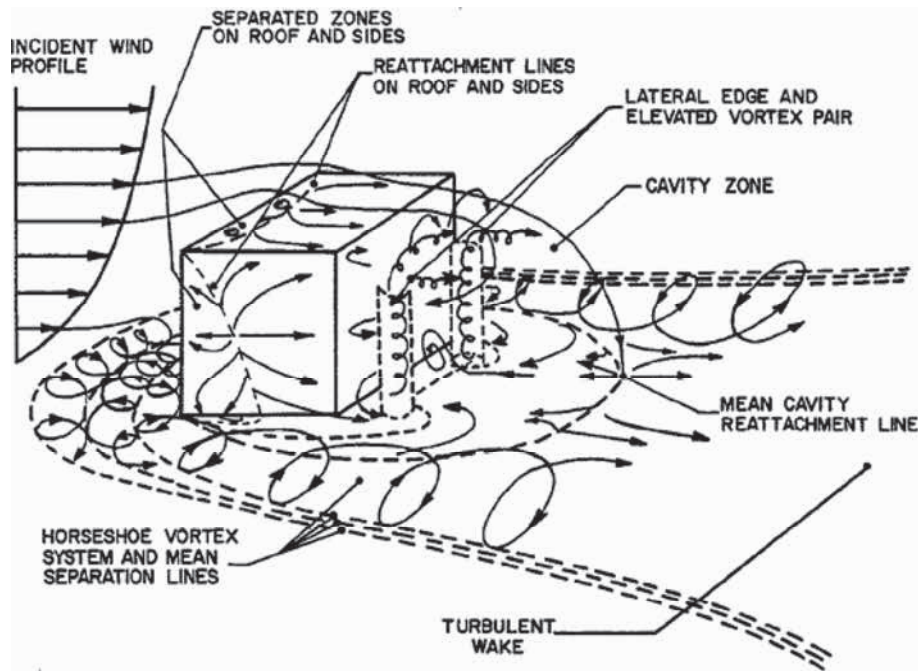

The diagram above shows how gentle winds would be modified by the presence of a single building. Air moving around the building would move upward, downward, and in lateral directions as it encountered the building's face. Complicated eddy currents would be set up that would carry suspended droplets of sarin or evaporated gas vapors to various locations near the ground. If there are open basement windows, heavier than air sarin gas or droplets could settle into those areas causing a higher concentration of sarin relative to other locations. In a residential area there would be many buildings and alleys that would channel the winds into a relatively dispersed plume-pattern. This is why the width of a plume passing on the ground will be substantially modified relative to what would occur if the plume were simply flowing over an open field. These subtle and unpredictable air motions would result in the unlucky death or lucky survival of individuals who are subject to such an attack.

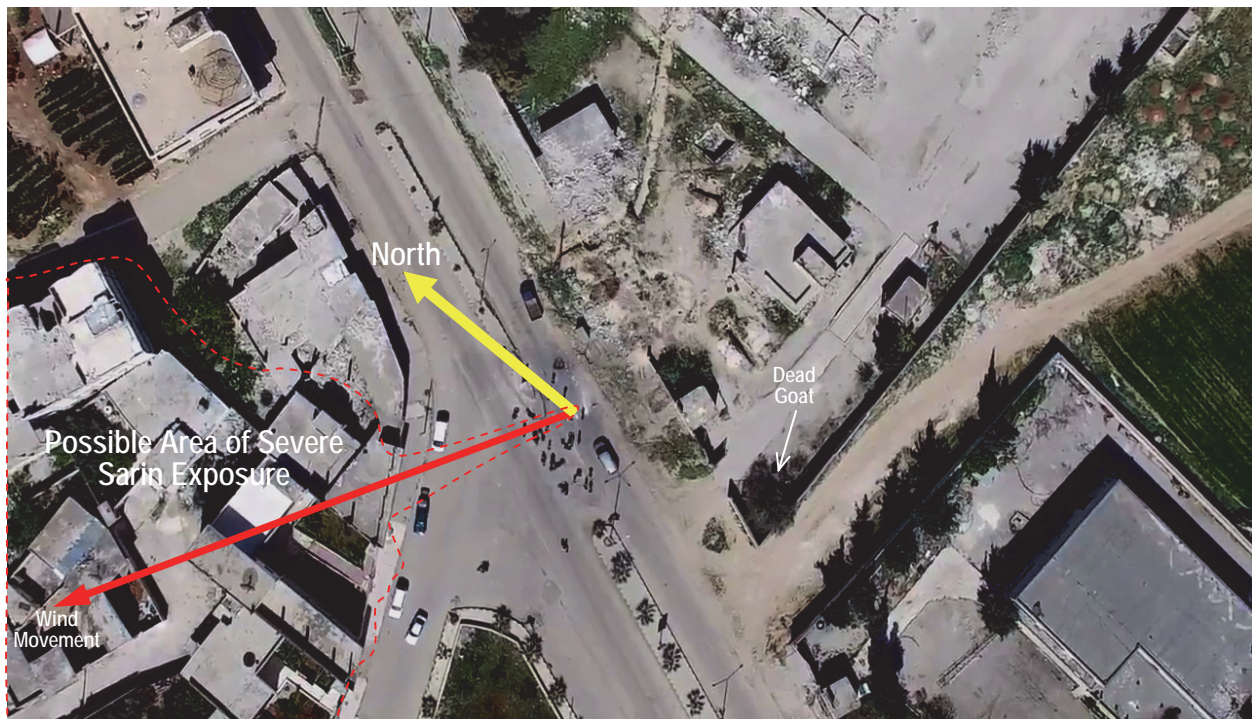

A purely notional estimate of the area that would have been immediately subjected to high concentrations of sarin droplets and gas is shown in red. This purely notional estimate assumes that sarin was mostly released near ground level. As a result, it would have been carried downwind at ground-level. The low winds would wind their way around building structures and channel the sarin gas into unpredictable directions. The plume would tend to spread more widely than would be the case if the area were simply an open field, which would allow air to flow without the obstructions created by buildings. This area would have been filled with dead people following the attack. Note the location of a dead goat in an area upwind of the deadly sarin-plume. This will be discussed shortly.

In spite of the fact that the alleged massively affected area immediately adjacent to the crater would have been filled with many hundreds of dead victims, there is absolutely no mention of this area of mass deaths in any of the numerous journalistic accounts from that location. It is as if the dead were killed on the moon, rather than only tens of meters away.



Video images from the second of two videos of the area where the alleged sarin-releasing crater was extensively photographed and reported on by local journalists in Khan Sheikhoun. Note that the journalist is walking in the opposite direction of what would have been a lethal plume of sarin that would have entered a densely populated area at the same distance from the crater but in the opposite direction.

In spite of the hundreds of people who would have died only tens of meters to the west northwest of the crater, the journalists instead turn in the opposite direction from the area where mass deaths would have occurred.

Careful examination of the video of the dead goat shown in these journalistic accounts show evidence that the goat carcass was dragged along the ground to the point where the journalists claim it was poisoned in the sarin attack.



Thus, the big news in Khan Sheikhoun was apparently, *Dead Goat Drags Its Own Carcass to the Upwind Scene of the Alleged Sarin Attack!*

Summary and Conclusions

There can be no doubt that using any form of murderous weapon, chemicals or otherwise, against innocent civilians and children constitute crimes against humanity.

It is also clear that there are multiple groups in Syria who have, or who have had access to the precursor chemicals needed to produce sarin. There is substantial evidence that the nerve agent attack of August 21, 2017 in Damascus might not have been executed by the Syrian government. President Barack Obama reported in an April 2016 interview in *The Atlantic* that he was told in September 2013 by the then Director of National Intelligence, James Clapper, that the US intelligence community did not believe that the evidence clearly showed that the Syrian government was the source of this attack.

Human Rights Watch should have considered the possibility that at least some of these attacks could be perpetrated by groups who are interested in manipulating the United States into taking military actions that would support their political and military objectives against the Syrian government. If this is the case, *Human Rights Watch* could be inadvertently encouraging these groups to continue murdering innocent civilians and children in pursuit of this objective.

It is not foreseeable that when multiple groups are all engaged in routine wartime atrocities that one of the groups will suddenly transform itself into a moral and just winner while all the others would surely continue their monstrous behavior.

We repeat the summary of conclusions from the introduction to this article for the convenience of the reader:

1. There is no forensic evidence presented in the *HRW* report to support the allegation that the munition used to deliver sarin was a KhAB 250 or 500 "standard" Russian munition.
2. There is no forensic evidence of any kind of debris in and around in the crater that indicates any form of airdropped sarin dispensing munition.
3. There is no forensic evidence of a calamitous killing of a large part of the population of a densely populated area immediately adjacent to the alleged crater where massive amounts of sarin were supposed to have been released.
4. Interviews described in the *HRW* report were not verified in any way.
One of the most striking omissions in the panoply of claims put forth in the *HRW* report is the lack of any video evidence (or verbal accounts) of mass casualties and chaos in the densely populated area immediately adjacent to the crater that would have had to be the alleged sarin kill-zone.
Instead, the only indication of a death near the crater is videos of a goat carcass that was obviously dragged across the ground to the location. The same people who took these videos appear to be among the "reliable" sources of interview evidence cited by the *HRW* report. These same journalists showed a dead carcass of a goat supposedly adjacent to the crater rather than the area where mass casualties would have occurred an equally short distance away.
5. Although there are pictures of victims that indicate poisoning by sarin or other organophosphates that act as nerve agents, there is no forensic indication that these photographs are actually victims of sarin poisoning in the alleged nerve agent attack of April 4, 2017 in Khan Sheikhoun. If the victims could be connected with an event in Khan Sheikhoun on April 4, their symptoms could easily be the result of poisoning from organophosphates pesticides and from gases and smoke products generated in fires that often occur in industrial accidents. As such, there is no basis to rule out a claim made by the Russians that an ammunition dump that was adjacent to a heavily populated area was hit using a conventional explosive bomb. While this certainly is not proof of the Russian claim, neither is there any proof in the *HRW* report of a sarin release at the crater.
6. Given that there is substantial evidence that groups other than the Syrian government possess sarin precursors, indications of sarin poisoning do not alone indicate that the Syrian government was the source of the sarin, assuming the observed medical effects were from sarin.